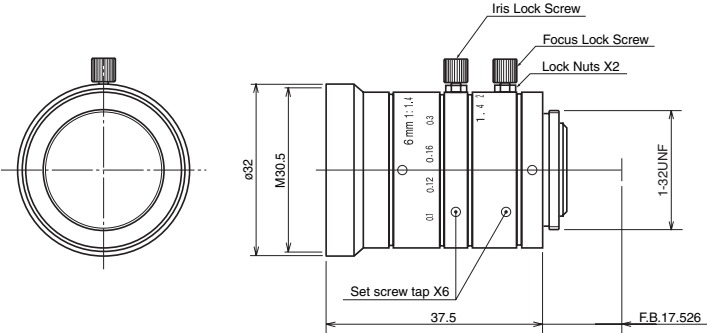

HM6WI MEGA-PIXEL 1/2" 6mm F1.4

Focal Length	6mm	
Iris	F1.4-16	
Angular Field of View (H x V)	1/2"	57.4° x 44.3°
	1/3"	—
Distortion (TV)	1/2"	-0.96%
	1/3"	—
Minimum Object Distance	0.2m	
Optical Back Focal Distance	12.32mm (In Air)	
Resolution Center/Corner	100 line/mm / 80 line/mm	
Filter Size	30.5mm P0.5	
Mount	C-Mount	
Operation Temperature	-10° to +45°C	
Weight	65g	

- High resolution 1.0 Mega-Pixel
- Low distortion
- Metal body and mount
- Locking screws with securing hex bolt
- Iris click stops

SM25WI MEGA-PIXEL 2/3" 25mm F1.4

Focal Length	25mm	
Iris	F1.4-16	
Angular Field of View (H x V)	2/3"	20.1° x 15.1°
	1/2"	—
	1/3"	—
Distortion (TV)	2/3"	-0.28%
	1/2"	—
	1/3"	—
Minimum Object Distance	0.25m	
Optical Back Focal Distance	13.13mm (In Air)	
Resolution Center/Corner	140 line/mm / 100 line/mm	
Filter Size	25.5mm P0.5	
Mount	C-Mount	
Operation Temperature	-10° to +45°C	
Weight	45g	

- High resolution 1.4 Mega-Pixel
- Low distortion
- Metal body and mount
- Locking screws with securing hex bolt
- Iris click stops

